

Experiment #2

Standing Wave Measurements

Name: _____ Partners: _____ Group: _____

OBJECT:

The object of this experiment is to learn to measure VSWR with slotted line and VSWR meter.

EXPERIMENT SET-UPS:

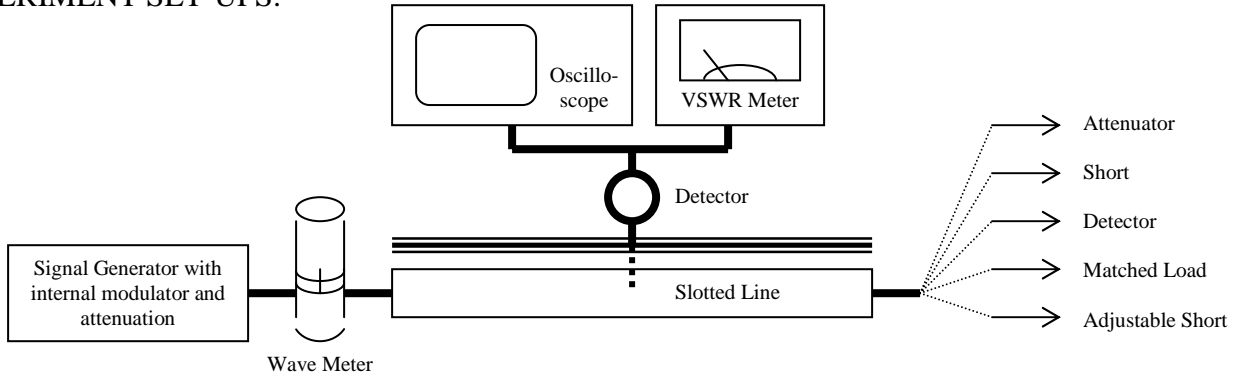

Fig. 1 Experiment Setup

GOALS:

With these set-ups, you are expected to measure the *wavelength*, *VSWR*, then calculate the measured frequency and compare the *accuracy* given by different equipments.

EQUIPMENTS: Correct the list if you are using different ones

Equipments	A	B	C	D	E
Oscilloscope	Tektronix 2235	Tektronix 2213	Tektronix 2215A	Tektronix 2236	Tektronix 2235A
Signal Generator	HP	HP	HP	HP	HP
VSWR Meter	HP 415	HP 415	HP 415	HP 415	HP 415
Wave Meter	HP	HP	HP	HP	HP
Slotted Line	Coaxial Cable	Coaxial Cable	Coaxial Cable	Waveguide	Waveguide

[EQUIPMENT FUNCTIONAL DESCRIPTION \(Brief\):](#)

Signal Generator:

It generates signal with the frequencies needed to propagate in the slotted line. It has internal modulator, which will be used in this experiment.

Slotted Line:

This line is a slotted co-axial line. It has a moving probe that probes the coax in order to sense the propagating signal. It acts like an antenna picking the signal radiated by the coax. A diode detector is attached to the probe. The diode (square law device) will have its output as the envelope of the sensed signal (power rather than voltage level).

The probe should be as outward (away from the coax) as possible in order to minimize reflections caused by its presence and limit the power input to the diode. More details are found in attachments

Wave Meter:

It is a variable size cavity resonator, which has an adjustable resonance frequency. When this cavity is adjusted to resonance using the dial, the working frequency will be indicated. As a result of resonance some power is absorbed by the resonator, accordingly, resonance condition should be removed after measuring the frequency. This meter is more accurate than the frequency indicator of the signal generator

VSWR Meter:

It uses the output of the detector to measure the VSWR. This meter makes measurements relatively; accordingly it needs to be normalized. To measure VSWR use the following steps:

- Set the VERNIER and GAIN dials to $\frac{1}{2}$. Set the EXPAND dial to Norm
- Find a voltage maximum on the slotted line. Using the VSWR meter it can be found by the point where the indicator deflects most towards the right.
- Change the RANGE (dB) dial until a reading can be observed on the meter
- Normalize the meter by setting this reading to 1 on the SWR scale using the VERNIER and GAIN dials
- Now find a minimum on the slotted line. You initially take VSWR measurement by reading its value on the SWR 1- 4 scale. Watch the indicator moving to the left while moving away from the maximum. **One of three cases will occur**

- VSWR < 1.3

A more accurate reading can be found by changing the EXPAND dial to “0” and reading the VSWR measurement from the upper SWR 1-1.3 scale

- 1.3 < VSWR < 4

VSWR measurement can be read directly from the middle SWR 1-4 scale

- VSWR > 4

Now the indicator will be at the utmost left. Increase the RANGE dial by 10 dB and take the reading from the lower SWR 3.2-10 scale.

If the indicator still goes to the utmost left, increase the RANGE dial by another 10 dB and take the reading from the middle SWR 1-4 scale multiplied by 10.

If the indicator still goes to the utmost left, increase the RANGE dial by another 10 dB and take the reading from the lower SWR 3.2-10 scale multiplied by 10.

Repeat the previous steps till the correct reading is found.

EXPERIMENT PROCEDURE:

1. In the set-up there are three ways to get an indication of the signal frequency. There is a frequency indicator on the **signal generator**, an adjustable calibrated **frequency meter** in series with the slotted line, and the **slotted line** itself.
2. With a short circuit terminating the line, record the readings of minima, measure the wavelength by moving the probe, and calculate the frequency.
 - (1) First reading: _____ cm
 - (2) Second reading: _____ cm
 - (3) $\lambda_g/2 = (2)-(1) =$ _____ cm
 - (4) $\lambda_g =$ _____ cm
 - (5) Frequency $f=c/\lambda =$ _____ GHz
 - (6) Note: $1/\lambda = \sqrt{\left(\frac{1}{\lambda_g}\right)^2 + \left(\frac{1}{2a}\right)^2}$ in waveguide
3. (7) Record the frequency reading of the frequency meter: _____ GHz
4. (8) Record the frequency indication on the signal generator: _____ GHz
5. The frequency meter should give the most accurate and precise indication. Using it as standard, determine the accuracy of the signal generator calibration and evaluate the accuracy of the frequency determination derived from wavelength measurements on the slotted line.
 - (9) Slotted line error = $[(7)-(5)/(7)] \times 100\% =$ _____ %
 - (10) Signal generator error = $[(7)-(8)/(7)] \times 100\% =$ _____ %
6. Although (5) may not be accurate, the actual wavelength on the slotted line should be used for the rest of calculations in this report.
7. Determine a position on the slotted line that is equivalent to the physical end of the line
 - (11) _____ cm.
8. With the line terminated in a coaxial detector and the detector output connected to the oscilloscope, vary the depth and position of the probe to see what effect it has on the transmitted power. From this exercise

you should conclude what probe depth is allowed if the measurements are not to be influenced by the measuring technique.

9. (11) will be considered the “load position” in all that follows. Make a plot according to the detector output as a function of fractional wavelengths from the load when the load is (12) a **short circuit**, (13) an **open circuit**, (14) a **matched load**, (15) an **attenuator**, (16) a **crystal detector**, and (17) a **load other than 50Ω**. Please be careful when you plot the curves. For detector, $V_{OUT} \propto V_{IN}^2$.

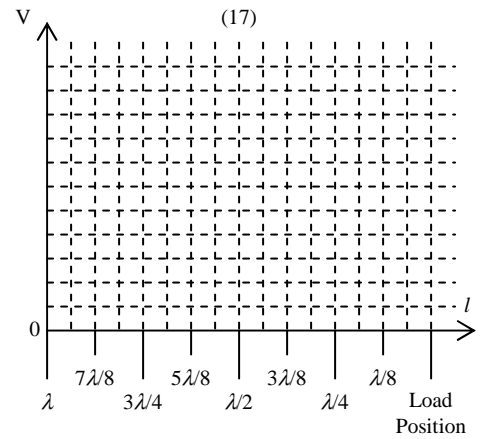
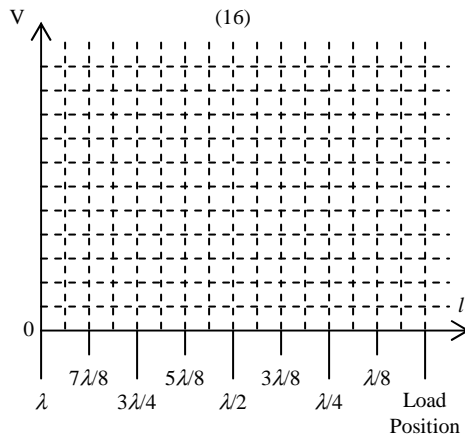
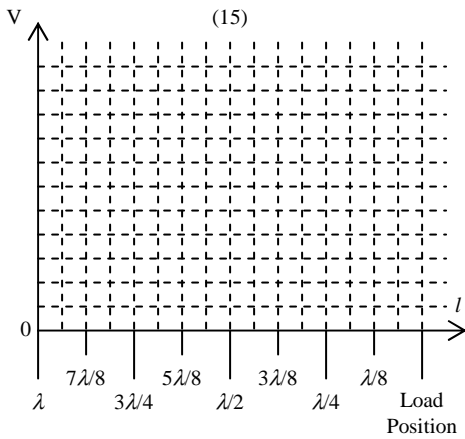
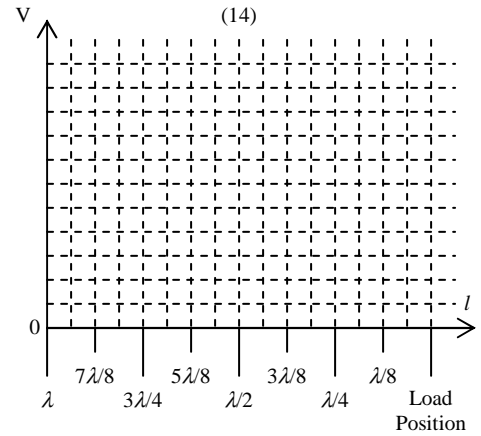
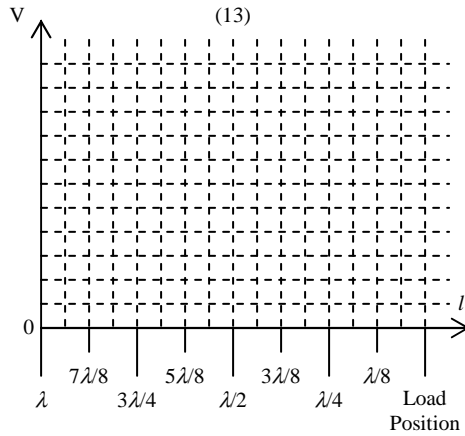
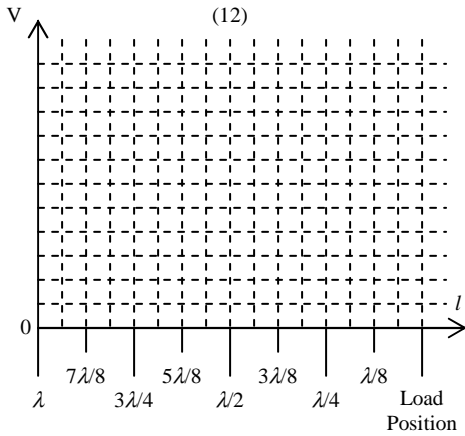

10. What is VSWR in each case above? (12) _____ (13) _____ (14) _____ (15) _____ (16) _____ (17) _____

Experiment #2

Standing Wave Measurements

Name: _____ Partners: _____ Group: _____

QUICK REFERENCE:

Experiment steps

1. Write down the equipments you use on your record (or report.)
2. Turn on all equipments
3. Wait a few minutes till the signal generator (or sweep oscillator) is warmed up.
4. Turn on "RF" on signal generator (or sweep oscillator)
5. Turn on "INT SQ WAVE" on signal generator (or sweep oscillator)
6. Adjust "INT SQ WAVE FREQ" to give you a maximal reading on the VSWR meter.
7. Adjust the detector probe to give you a maximal reading on the VSWR meter.
8. Note, you can adjust the probe depth. Don't let it go too deep into the slotted line, it might affect the field in the transmission line. So, adjust it to 'just right' that it will not affect the field and in the meanwhile it will not lose the accuracy of your measurement.
9. Put on the short circuit, measure the wavelength, calculate the frequency.
10. Calculate the frequency accuracy given by different equipments.
11. Find the "Load Position" by locating the minimum on the slotted line.
12. Put on different terminations, measure VSWR, and plot the curves (v vs. λ)
13. To measure VSWR, first find a maximum on the slotted line.
14. Set the VSWR meter to "1.0" by adjusting "RANGE" and "GAIN VERNIER"
15. Then find a minimum on the slotted line
16. The reading on VSWR meter is the VSWR of the load.
17. Detail operating instructions for HP 415D (E) SWR meter is attached below.

APPENDIX

Operating Instructions for Hewlett-Packard Model 415D (E) SWR Meters